

13D

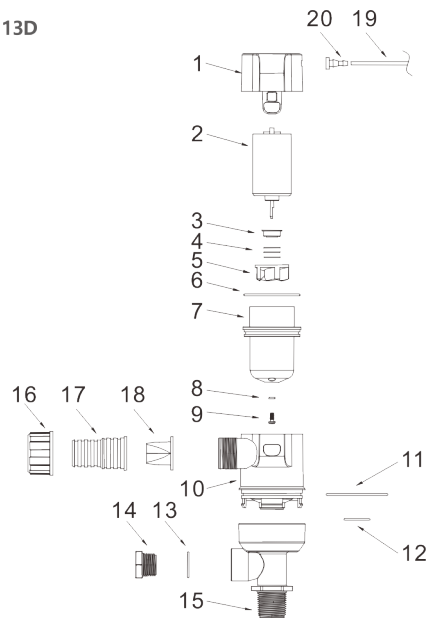

Key	Description	Quantity
1	Motor cover	1
2	motor	1
3	Motor protection cap	1
4	Oil Seal	3
5	Impeller	1
6	Motor sealing	1
7	Motor Cover	1
8	Screw sealing	2
9	Screw M3*8	2
10	Pump housing	1
11	Non-rotating seal	1
12	Water absorption seal	1
13	Interface seal	1
14	Interface plug	1
15	Short Tee	1
16	Pipe joint	1
17	Lock nut	1
18	Check valve	1
19	wire	2
20	Two-hole line card	1

13E

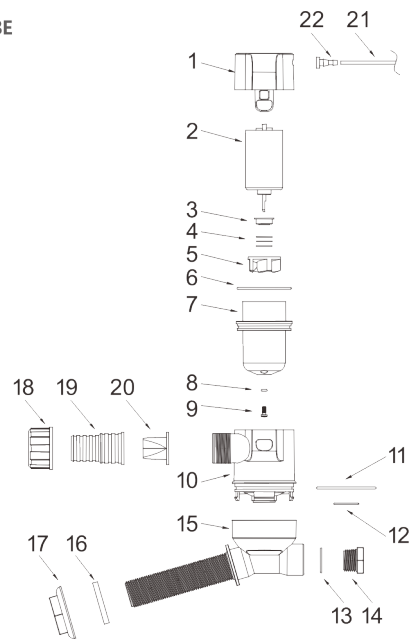

Key	Description	Quantity
1	Motor cover	1
2	motor	1
3	Motor protection cap	1
4	Oil Seal	3
5	Impeller	1
6	Motor sealing	1
7	Motor Cover	1
8	Screw sealing	2
9	Screw M3*8	2
10	Pump housing	1
11	Non-rotating seal	1
12	Water absorption seal	1
13	Interface seal	1
14	Interface plug	1
15	Inclined Tee	1
16	plate	1
17	Hex screw	1
18	Pipe joint	1
19	Lock nut	1
20	Check valve	1
21	wire	2
22	Two-hole line card	1

SEAFLO[®]

BILGE PUMP AND LIVELWELL BAITWELL PUMPS MANUALS



Purpose of this manual:

The purpose of this manual is to provide necessary information for product installation, operation and maintenance.

! CAUTION: Read this manual carefully before installing, using or servicing this product. Failure to follow the instructions within this manual could result in explosion, property damage, severe personal injury and/or death.

User safety:

General safety rules. These are safety rules that apply:

- Always keep work area clean
- Pay attention to the risks presented by gas and vapors in the work area
- Avoid all electrical dangers. Pay attention to the risks of electric shock or arc flash hazards
- Always bear in mind the risk of drowning, electrical accidents and burn injuries

! DANGER: This product is not intended for damage control or to deal with flooding resulting from hull damage. This product is intended to be used in Bilge Pumping Systems for small craft with a hull length up to 24 meters. Bilge Pumping Systems are limited to normal amounts of water in an intact boat due to spray, rain, seepage, spillage, and occasional small amounts of water shipped from boat movements in heavy weather. Use of product in any other way could result in flooding, catastrophic damage to craft, serious personal injury, or death.

! WARNING: This pump is designed for use with fresh water and salt water ONLY. Use with any other hazardous, caustic, or corrosive material could result in damage to the pump and the surrounding environment, possible exposure to hazardous substances and injury.

Explanation:

1. The fittings are designed as a split quick connect joint, which adopts the split design of lock nut. This solution can quickly disassemble and replace the fitting without dismantling the water pipe which can meet the needs of most users. The lock nut is universal. 1-1/8"29mm 90° fitting sold separately with 360° rotation function to meet any angle requirement.

2. Pump Body 360° rotation function only available for 13C/13D/13E.



Rotation Function



13C/13D/13E Pump Body
Rotation Function



Split quick-connect joint
design no need to disconnect
base or plumbing when
replacing pump.

Suitable for 600-800-1100-1500-2000GPH Only

Accessories:



Standard Straight Fitting
1" (25mm) or
1-1/8" (29mm)

13A/B/C/D/E 600-800-1100GPH



Optional Angle Fitting
1-1/8" (29mm)



Straight Fitting
1-1/8" (29mm)

13A/B 1500-2000GPH



Elbow Fitting
1-1/8" (29mm)



Straight Fitting
1-1/2" (40mm)

13A 3000-3700-4700GPH



Straight Fitting
2" (52mm)

Instructions:

Dimension Drawings:

13A/13B 600-800-1100GPH

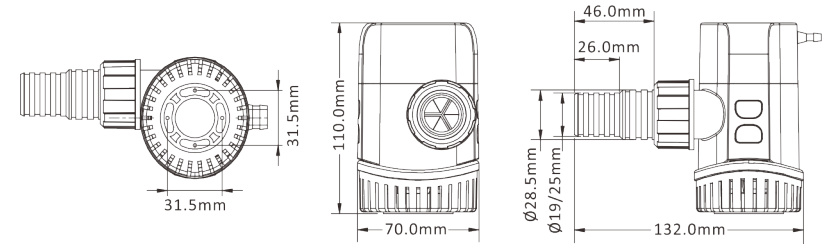

13A/13B 1500-2000GPH

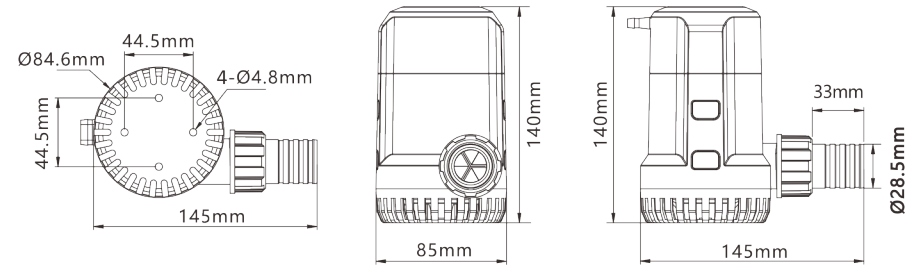

13A 3000-3700-4700GPH

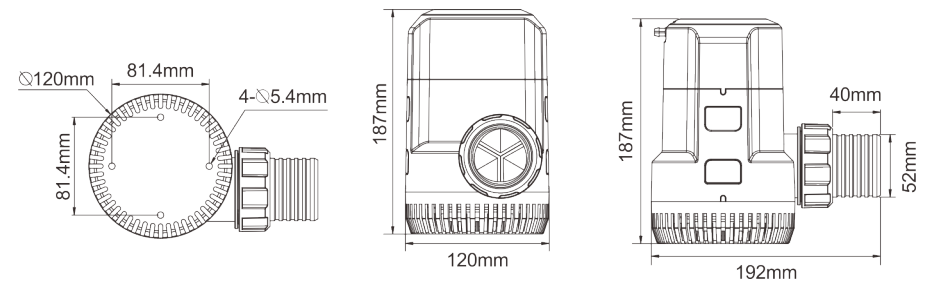

13C

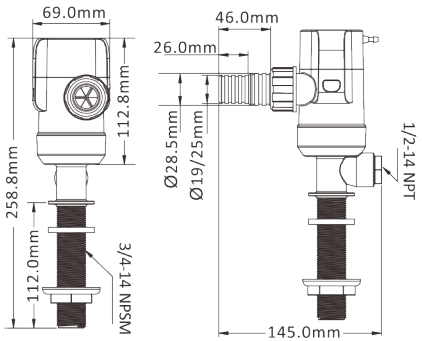

13D

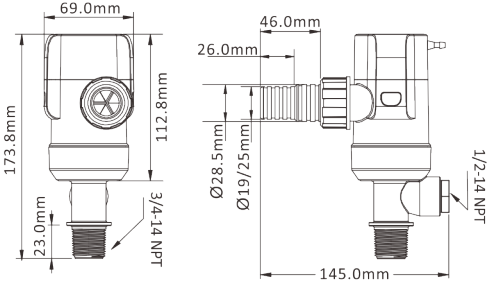

13E

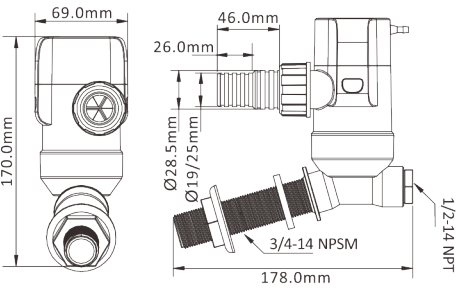

Schematic diagram of replacing motor components:

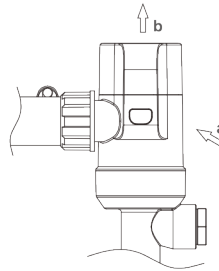

Press firmly on the motor assembly buttons on both sides
Push the button and pull out the motor assembly.

Wiring Diagrams:

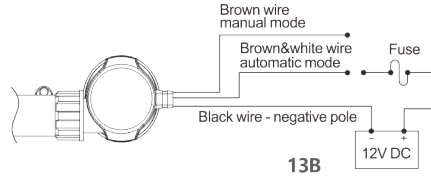
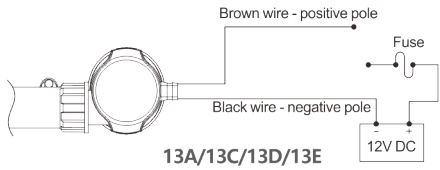

Typical Installation:

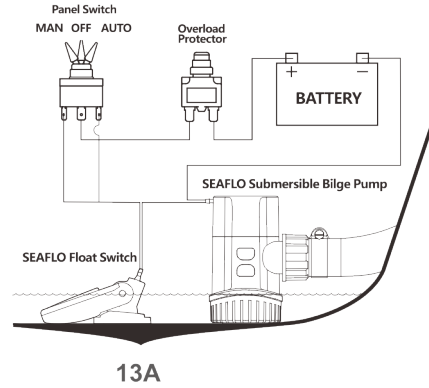

Running for 0.5 sec
ON
OFF
Check for water every 2.5 min

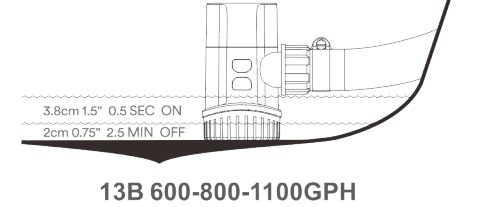

13B 600-800-1100GPH

Running for 0.5 sec
ON
OFF
Check for water every 2.5 min

4.5cm 1.77\"/>

13B 1500-2000GPH

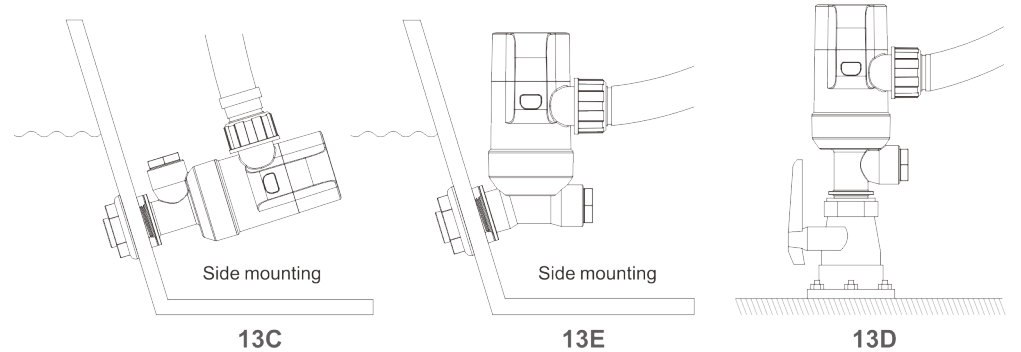

Operating modes:

13A 600-800-1100GPH

Pump starts when water reaches 3.8cm/1.5" level, and stops when water level down to 2cm/0.75" for 15 seconds.

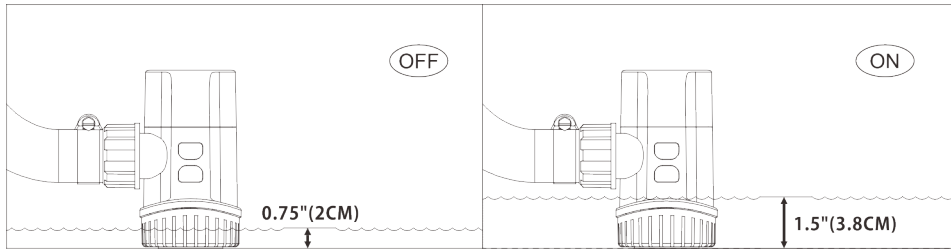

13B 600-800-1100GPH

Pump automatically turns on every 2.5 minutes. When the current is below 1.25A or above 8A, pump will stop running. And it will try to start again after 2.5 minutes stopping. When the pump detects that the current at the water level exceeds 1.25A, it will work normally to pump water away.

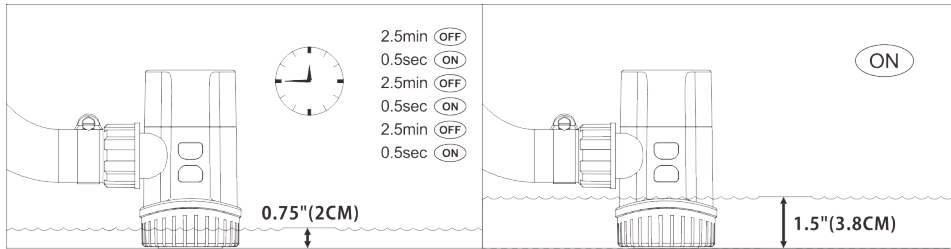

13A 1500-2000GPH

Pumps starts when water reaches 4.5cm/1.77" level, and stops when water level down to 1~3cm/0.39~1.18"

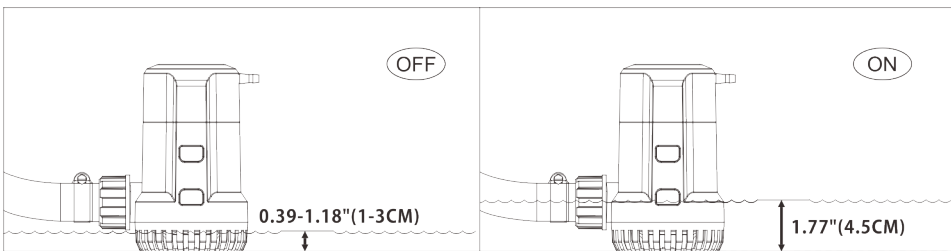

13B 1500-2000GPH

Pumps starts when water reaches 4.5cm/1.77" level, and stops when water level down to 1~3cm/0.39~1.18".

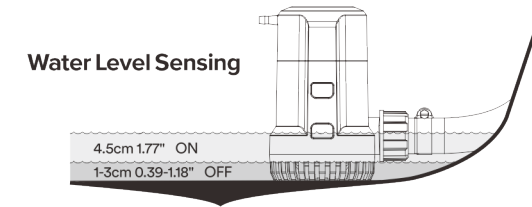

13A 3000-3700-4700GPH

Pump starts when water reaches 4cm/1.57" level, and stops when water level down to 2cm/0.75" for 15 seconds.

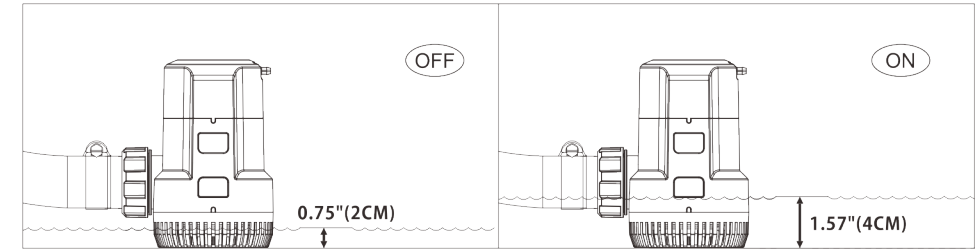

STANDARD PUMP CONFIGURATIONS

Flowrate	Volts	Current	Fuse	Wire Lead	Outlet Dia.	N.W./G.W.
600GPH	12V	2.5A	4.0A	3' (1 m)	3/4" (19mm) 1 1/8" (29mm)	0.40KG/0.47KG
600GPH	24V	1.5A	3.0A	3' (1 m)		0.40KG/0.47KG
800GPH	12V	3.5A	6.0A	3' (1 m)	1" (25mm) 1 1/8" (29mm)	0.40KG/0.47KG
800GPH	24V	2.0A	4.0A	3' (1 m)		0.40KG/0.47KG
1100GPH	12V	4.0A	8.0A	3' (1 m)	1 1/8" (29mm)	0.40KG/0.47KG
1100GPH	24V	2.5A	5.0A	3' (1 m)		0.40KG/0.47KG
1500GPH	12V	4.5A	8.0A	3' (1 m)	1 1/8" (29mm)	0.65KG/0.75KG
1500GPH	24V	2.5A	5.0A	3' (1 m)		0.65KG/0.75KG
2000GPH	12V	7.5A	15.0A	3' (1 m)	1 1/2" (40mm) 2" (52mm)	0.78KG/0.88KG
2000GPH	24V	4.0A	8.0A	3' (1 m)		0.78KG/0.88KG
3000GPH	12V	12.0A	20.0A	3' (1 m)	1 1/2" (40mm) 2" (52mm)	2.10KG/2.20KG
3000GPH	24V	6.0A	10.0A	3' (1 m)		2.10KG/2.20KG
3700GPH	12V	14.0A	25.0A	3' (1 m)	1 1/2" (40mm) 2" (52mm)	2.10KG/2.20KG
3700GPH	24V	7.0A	12.0A	3' (1 m)		2.10KG/2.20KG
4700GPH	12V	16.0A	25.0A	3' (1 m)	1 1/2" (40mm) 2" (52mm)	2.10KG/2.20KG
4700GPH	24V	8.0A	14.0A	3' (1 m)		2.10KG/2.20KG

Remarks:600-1500-2000GPH is available for 13A/13B only,3000-3700-4700GPH is available for 13A only.

Configurations:

13A 600-800-1100GPH

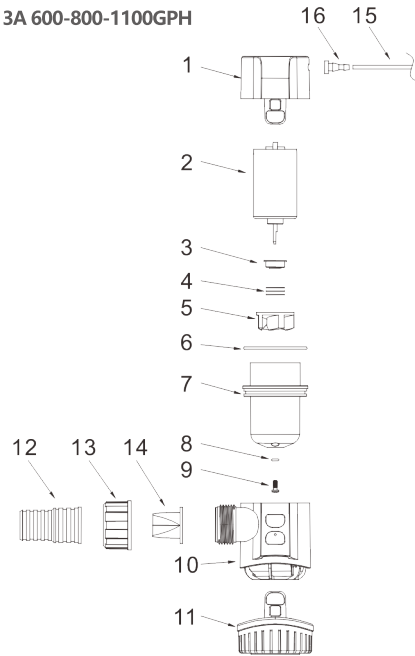

Key	Description	Quantity
1	Motor cover	1
2	motor	1
3	Motor protection cap	1
4	Oil Seal	3
5	Impeller	1
6	Sealing rubber ring	1
7	Motor Cover	1
8	Screw sealing	2
9	Screw M3*8	2
10	Pump housing	1
11	filter	1
12	Pipe joint	1
13	Lock Nut	1
14	Check Valve	1
15	wire	2
16	Two-hole line card	1

13B 600-800-1100GPH

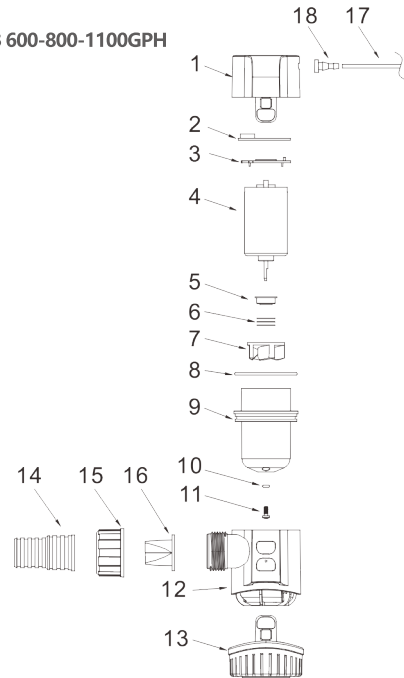

Key	Description	Quantity
1	Motor cover	1
2	PCB board	1
3	PCB board bracket	1
4	motor	1
5	Motor protection cap	1
6	Oil seal	3
7	Impeller	1
8	Sealing rubber ring	1
9	Motor cover	1
10	Screw sealing	2
11	Screw M3*8	2
12	Pump housing	1
13	filter	1
14	Pipe joint	1
15	Lock Nut	1
16	Check valve	1
17	wire	3
18	Three-hole line card	1

13A 1500GPH

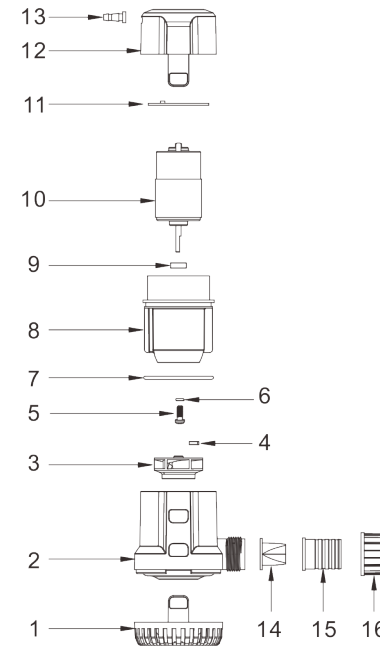

Key	Description	Quantity
1	Strainer	1
2	Housing	1
3	Impeller	1
4	Probe Holder	1
5	Screw	2
6	Sealing 1	2
7	Sealing 2	1
8	Motor Housing	1
9	Oil Seal	1
10	Motor	1
11	Circuit Board	1
12	Pump Housing	1
13	Wire Buckle	1
14	Check Valve	1
15	Fitting	1
16	Fitting Cover	1

13B 1500GPH

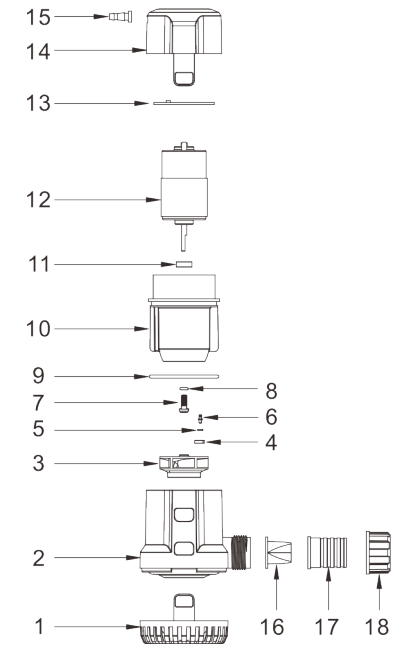

Key	Description	Quantity
1	Strainer	1
2	Housing	1
3	Impeller	1
4	Probe Holder	1
5	Screw	2
6	Sealing 1	2
7	Sealing 2	1
8	Motor Housing	1
9	Oil Seal	1
10	Motor	1
11	Circuit Board	1
12	Pump Housing	1
13	Wire Buckle	1
14	Check Valve	1
15	Fitting	1
16	Fitting Cover	1
17	Fitting	1
18	Fitting Cover	1

13A 2000GPH

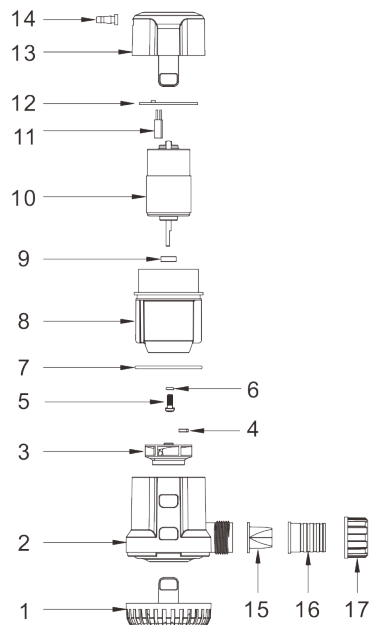

Key	Description	Quantity
1	Strainer	1
2	Housing	1
3	Impeller	1
4	Probe Holder	1
5	Screw	2
6	Sealing 1	2
7	Sealing 2	1
8	Motor Housing	1
9	Oil Seal	1
10	Motor	1
11	Heat Protector	1
12	Circuit Board	1
13	Pump Housing	1
14	Wire Buckle	1
15	Check Valve	1
16	Fitting	1
17	Fitting Cover	1

13B 2000GPH

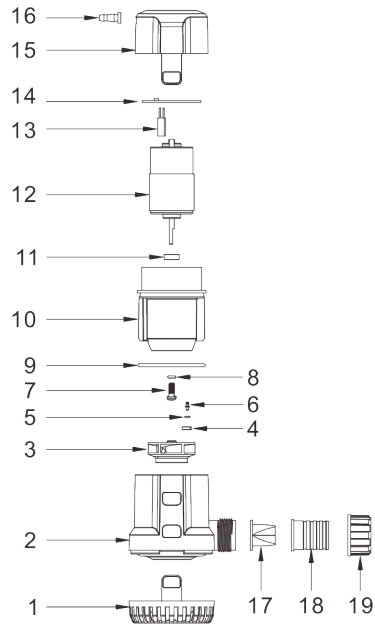

Key	Description	Quantity
1	Strainer	1
2	Housing	1
3	Impeller	1
4	Probe Holder	1
5	Sealing 3	2
6	Probe	2
7	Screw	2
8	Sealing 1	2
9	Sealing 2	1
10	Motor Housing	1
11	Oil Seal	1
12	Motor	1
13	Heat Protector	1
14	Circuit Board	1
15	Pump Housing	1
16	Wire Buckle	1
17	Check Valve	1
18	Fitting	1
19	Fitting Cover	1

13A 3000-3700-4700GPH

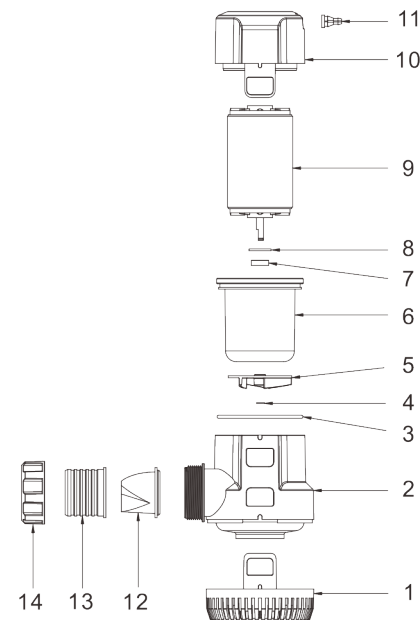

Key	Description	Quantity
1	Strainer	1
2	Housing	1
3	Sealing rubber ring	1
4	Snap ring	1
5	Impeller	1
6	Motor Housing	1
7	Oil Seal	1
8	Seal Base	1
9	Motor	1
10	Pump Housing	1
11	Wire Buckle	1
12	Check Valve	1
13	Fitting	1
14	Fitting Cover	1

13C

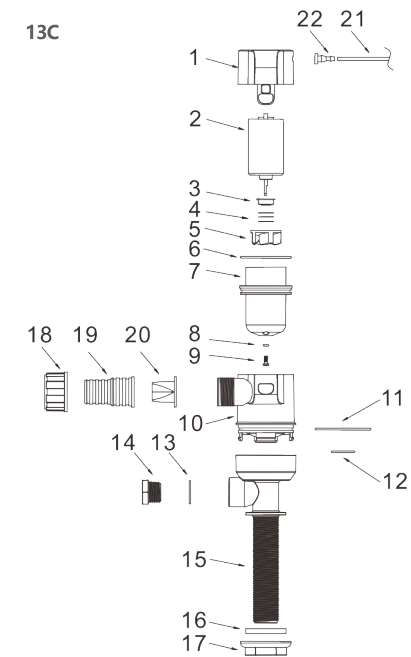

Key	Description	Quantity
1	Motor cover	1
2	motor	1
3	Motor protection cap	1
4	Oil Seal	3
5	Impeller	1
6	Motor sealing	1
7	Motor Cover	1
8	Screw sealing	2
9	Screw M3*8	2
10	Pump housing	1
11	Non-rotating seal	1
12	Water absorption seal	1
13	Interface seal	1
14	Interface plug	1
15	Straight tee	2
16	plate	1
17	Hex nuts	1
18	Pipe joint	1
19	Lock nut	1
20	Check valve	1
21	wire	2
22	Two-hole line card	1